

KPT-904

2-WAY BEHIND THE SCREEN CINEMA SYSTEM



KLIPSCH PROFESSIONAL | CINEMA | DATA SHEET



RECOMMENDED USE

 **UP TO 200 SEATS** (approximately 2800 ft² or 260 m²)

PRODUCT OVERVIEW

Once movie-goers experience the unbridled dynamics and intense realism of the KPT-904, they will have a new favorite theater for life. A mid-sized screen and stage loudspeaker system, it is especially suited for stadium seating.

The higher frequencies are handled by the KPT-904-HF, which uses the KDE-75-8P, 3" titanium diaphragm compression driver mated to the K-691 horn. This advanced Tractrix[®] horn geometry and compression driver technology creates a large soundstage with well-defined imaging, resulting in a more genuine, lifelike sound. The bass punch is provided by the KPT-904-LF dual, 15", low-frequency cabinet.

The KPT-904 delivers sensational performance and accurate coverage control, all at a remarkable price. It is available in a Bi-amp version and with a passive processor for mono-amp operation.

DESIGNED AND MADE IN THE USA USING DOMESTIC AND IMPORTED COMPONENTS

In 1946, Paul W Klipsch, genius & maverick, hand-built his first loudspeaker in a tin shed with the intention of bringing live music into his living room. Remember great sound? We do, too. Today, Klipsch's cinema speakers are made in the USA, by proud craftsmen in Hope, Arkansas. Just like PWK intended.

AVAILABLE VERSIONS

KPT-904-B

Bi-amp version without passive processor

KPT-904-M

Includes passive processor for Mono-amp operation

SYSTEM COMPONENTS

	KPT-904-B	KPT-904-M
HF/MF	KPT-904-HF	KPT-904-HF
LF	KPT-904-LF	KPT-904-LF
NETWORK	-	KPT-904-N2

SYSTEM SPECIFICATIONS

FREQUENCY RESPONSE ¹ (+/- 3 dB)	45 Hz - 19 kHz
FREQUENCY RANGE (-10 dB)	32 Hz - 20 kHz
SENSITIVITY ²	105 dB
MAXIMUM SPL ⁴	127 dB
HORIZONTAL COVERAGE	90° +/- 20° 250 Hz - 14 kHz
VERTICAL COVERAGE	60° +/- 20° 2 kHz - 19 kHz
DIRECTIVITY INDEX (DI)	8 dB
DIRECTIVITY FACTOR (Q)	6.3
HEIGHT	55.5" (141cm)
WIDTH	27.25" (69.22cm)
DEPTH	17.75" (45.1cm)
WEIGHT	156 lbs. (71 kg)

¹ Frequency response behind a screen relative to X-curve and with active processing applied

² SPL at 1M, half-space anechoic with 2.83V input

³ AES standard, continuous pink noise, 6 dB peaks

⁴ Calculated at 1M half-space at power handling input

RECOMMENDED MINIMUM AMPLIFIER POWER



TRANSDUCER	AMPLIFIER POWER RATING
MONO-AMP	800W into 4 ohms
LF (BI-AMP)	800W into 4 ohms
HF (BI-AMP)	100W into 8 ohms

KPT-904

2-WAY BEHIND THE SCREEN CINEMA SYSTEM



KLIPSCH PROFESSIONAL | CINEMA | DATA SHEET

	KPT-904-B		KPT-904-M																		
	HF	LF	HF/LF																		
SENSITIVITY²	108.5 dB	105.5 dB	105 dB																		
POWER HANDLING³	50W (20V)	800W (58V)	400W (37V)																		
POWER HANDLING (PEAK)	200W	3200W	1600W																		
MAXIMUM SPL⁴	125.5 dB	131 dB	127 dB																		
MAXIMUM SPL (PEAK)	131.5 dB	137 dB	133 dB																		
NOMINAL IMPEDANCE	8 ohm	4 ohm	3.5 ohm																		
	<div style="text-align: center;">  KPT-904-HF </div> <table border="1"> <tr> <td>HIGHPASS CROSSOVER</td> <td colspan="2">900 Hz Linkwitz Riley 24 dB</td> </tr> <tr> <td>PEQ1</td> <td>1.52 kHz</td> <td>Q: 1.2 Gain: -5 dB</td> </tr> <tr> <td>PEQ2</td> <td>3.7 kHz</td> <td>Q: 5 Gain: -3 dB</td> </tr> <tr> <td>PEQ3</td> <td>1.36 kHz</td> <td>Q: 5 Gain: -2 dB</td> </tr> <tr> <td>HF DELAY</td> <td colspan="2">0.104 ms</td> </tr> <tr> <td>OUTPUT GAIN</td> <td colspan="2">0 dB</td> </tr> </table>		HIGHPASS CROSSOVER	900 Hz Linkwitz Riley 24 dB		PEQ1	1.52 kHz	Q: 1.2 Gain: -5 dB	PEQ2	3.7 kHz	Q: 5 Gain: -3 dB	PEQ3	1.36 kHz	Q: 5 Gain: -2 dB	HF DELAY	0.104 ms		OUTPUT GAIN	0 dB		<div style="text-align: center;"> ACTIVE PROCESSOR SETTINGS ARE NOT REQUIRED FOR MONO-AMP OPERATION </div>
HIGHPASS CROSSOVER	900 Hz Linkwitz Riley 24 dB																				
PEQ1	1.52 kHz	Q: 1.2 Gain: -5 dB																			
PEQ2	3.7 kHz	Q: 5 Gain: -3 dB																			
PEQ3	1.36 kHz	Q: 5 Gain: -2 dB																			
HF DELAY	0.104 ms																				
OUTPUT GAIN	0 dB																				
	<div style="text-align: center;">  KPT-904-LF </div> <table border="1"> <tr> <td>LOWPASS CROSSOVER</td> <td colspan="2">920 Hz Linkwitz Riley 24 dB</td> </tr> <tr> <td>PEQ1</td> <td>620 Hz</td> <td>Q: 3.2 Gain: +3 dB</td> </tr> <tr> <td>PEQ2</td> <td>200 Hz</td> <td>Q: 1 Gain: +1 dB</td> </tr> <tr> <td>PEQ3</td> <td>1.2 kHz</td> <td>Q: 5 Gain: -2 dB</td> </tr> <tr> <td>LF DELAY</td> <td colspan="2">0 ms</td> </tr> <tr> <td>OUTPUT GAIN</td> <td colspan="2">0 dB</td> </tr> </table>		LOWPASS CROSSOVER	920 Hz Linkwitz Riley 24 dB		PEQ1	620 Hz	Q: 3.2 Gain: +3 dB	PEQ2	200 Hz	Q: 1 Gain: +1 dB	PEQ3	1.2 kHz	Q: 5 Gain: -2 dB	LF DELAY	0 ms		OUTPUT GAIN	0 dB		
LOWPASS CROSSOVER	920 Hz Linkwitz Riley 24 dB																				
PEQ1	620 Hz	Q: 3.2 Gain: +3 dB																			
PEQ2	200 Hz	Q: 1 Gain: +1 dB																			
PEQ3	1.2 kHz	Q: 5 Gain: -2 dB																			
LF DELAY	0 ms																				
OUTPUT GAIN	0 dB																				

RECOMMENDED ACTIVE PROCESSOR SETTINGS

- ¹ Frequency response behind a screen relative to X-curve and with active processing applied
- ² SPL at 1M, half-space anechoic with 2.83V input
- ³ AES standard, continuous pink noise, 6 dB peaks
- ⁴ Calculated at 1M half-space at power handling input

Digital Signal Processing (DSP) equipment is required for the Bi-amp configuration of the KPT-904. Digital Signal Processing is not required for proper configuration of the mono-amp version (KPT-904-M), as the passive processor takes care of all the equalization/crossover requirements for the system.

The DSP parameters listed above are to establish crossover, gain, equalization and delay. They are recommended for the initial set-up evaluation and will yield the corresponding component specifications at the top of this page.

KPT-904

2-WAY BEHIND THE SCREEN CINEMA SYSTEM



KLIPSCH PROFESSIONAL | CINEMA | DATA SHEET

FREQUENCY RESPONSE

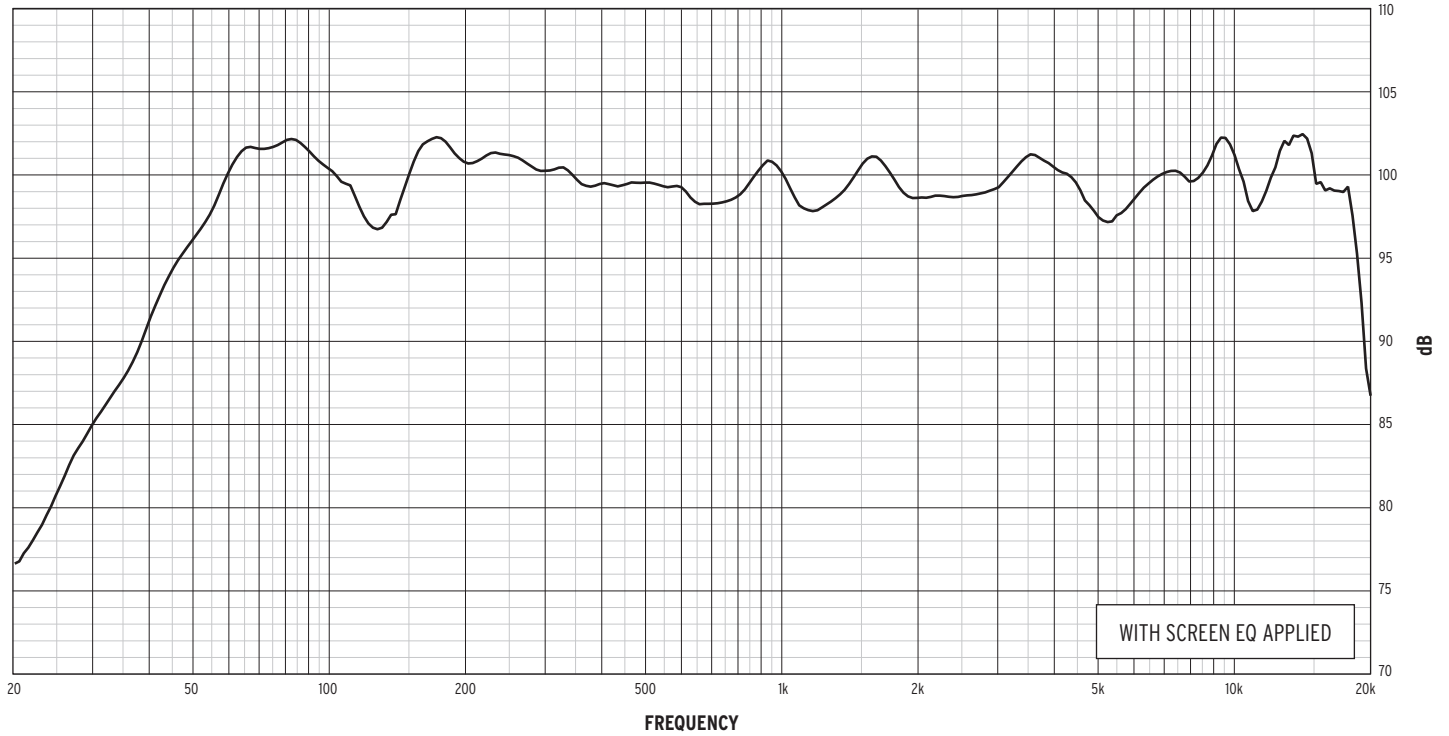

IMPEDANCE

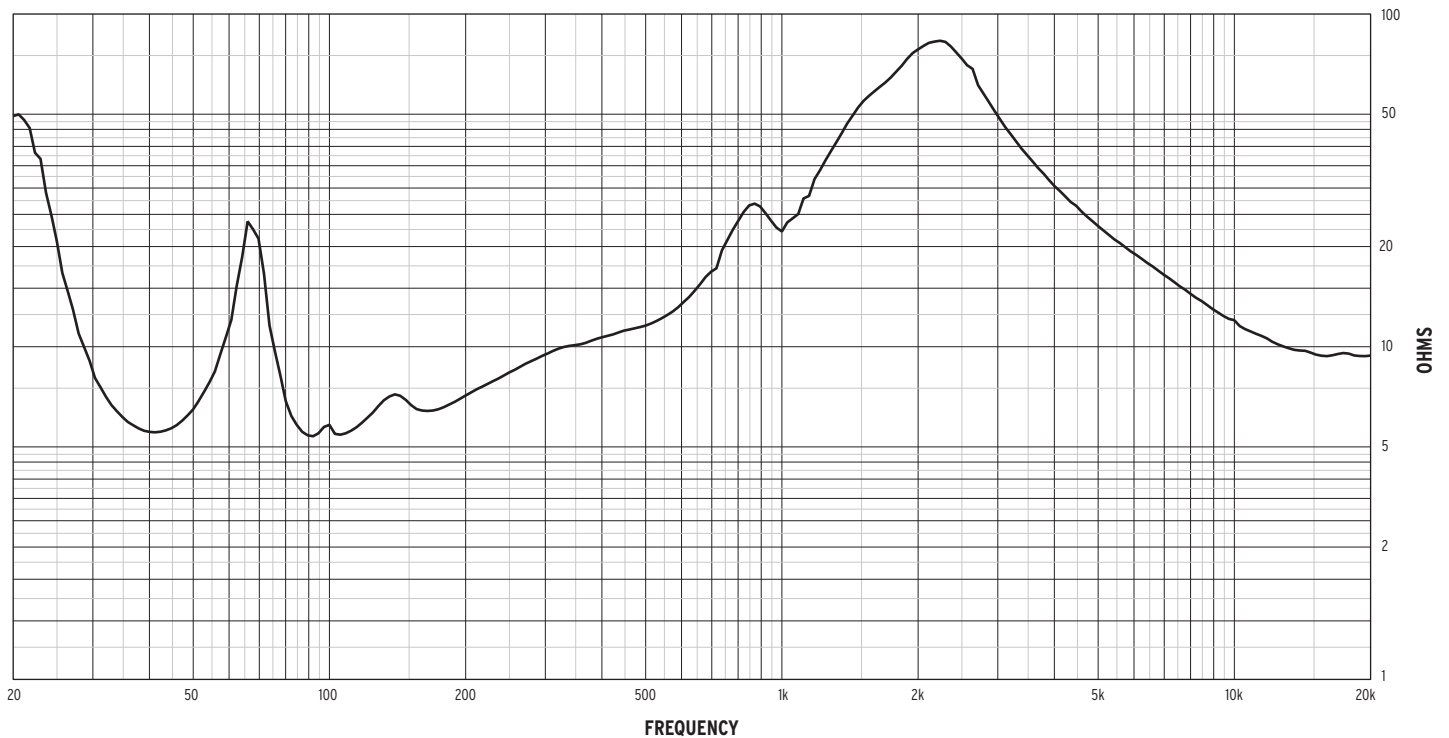

KPT-904

2-WAY BEHIND THE SCREEN CINEMA SYSTEM



KLIPSCH PROFESSIONAL | CINEMA | DATA SHEET

HORIZONTAL OFF AXIS TRANSFER FUNCTION LEFT

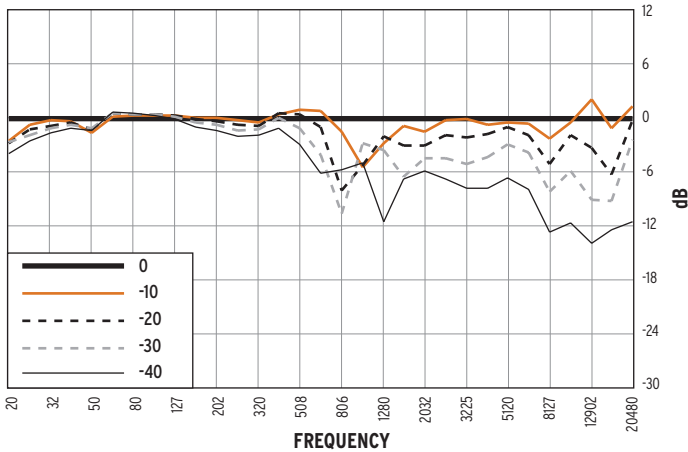

HORIZONTAL COVERAGE (-6dB)

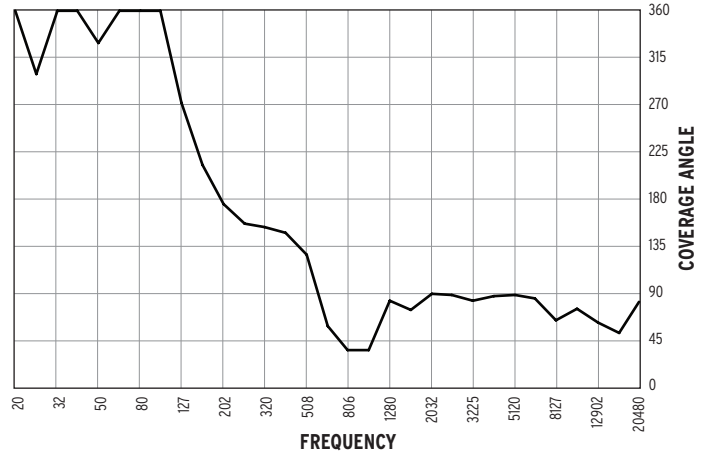

HORIZONTAL OFF AXIS TRANSFER FUNCTION RIGHT

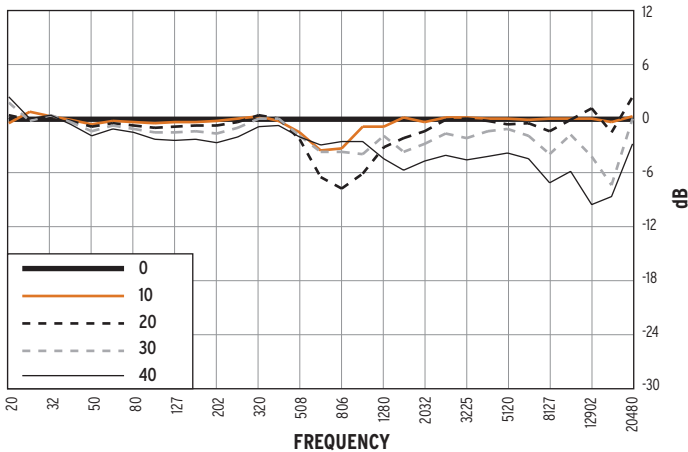

VERTICAL COVERAGE (-6dB)

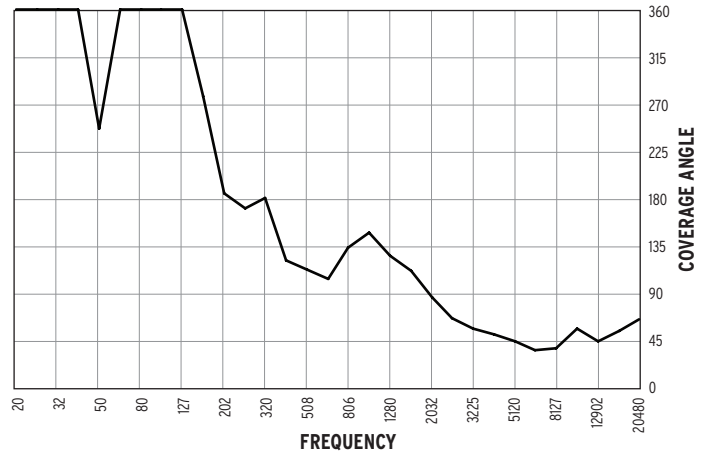

VERTICAL OFF AXIS TRANSFER FUNCTION

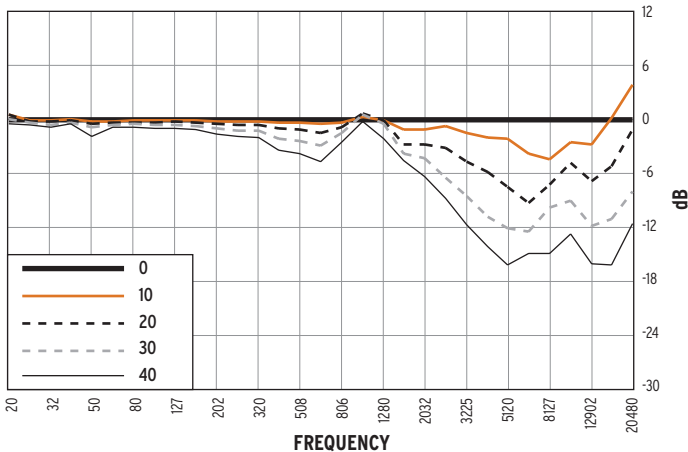

DIRECTIVITY INDEX

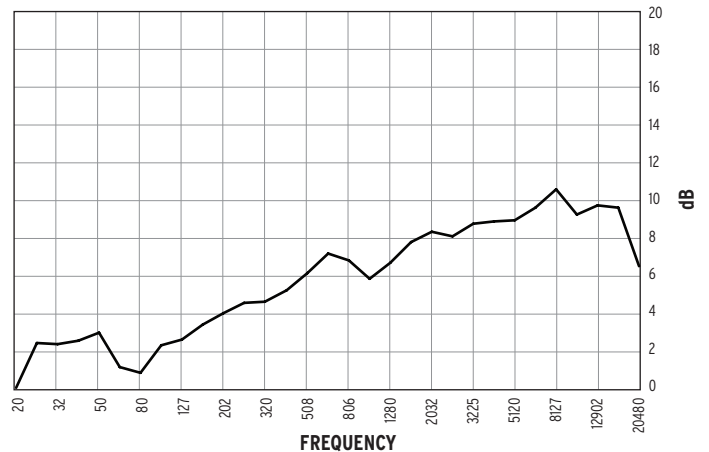

KPT-904

2-WAY BEHIND THE SCREEN CINEMA SYSTEM



Klipsch

KLIPSCH PROFESSIONAL | CINEMA | DATA SHEET

HORIZONTAL 1/3 OCTAVE POLARS

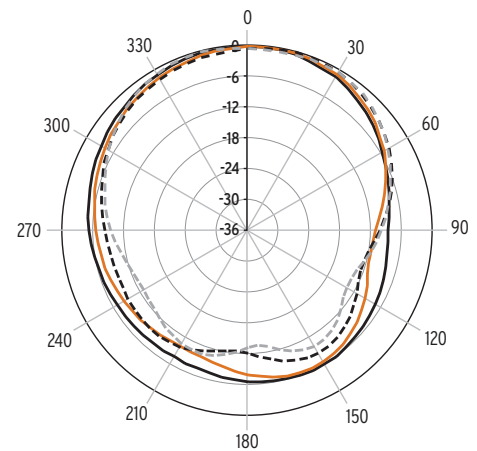
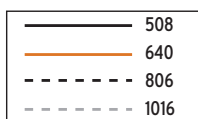
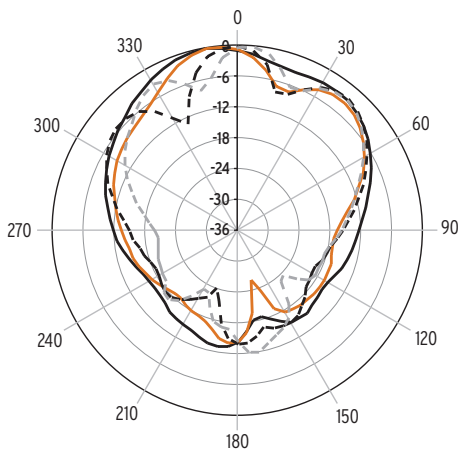
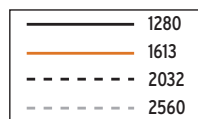
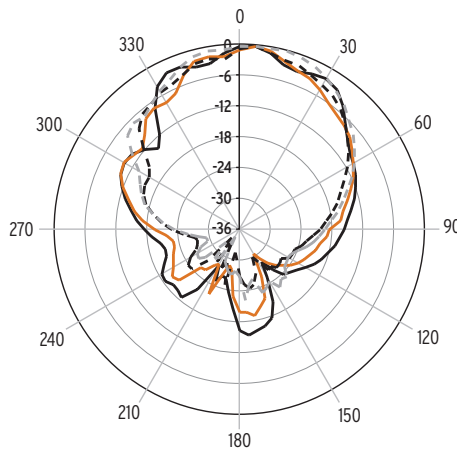
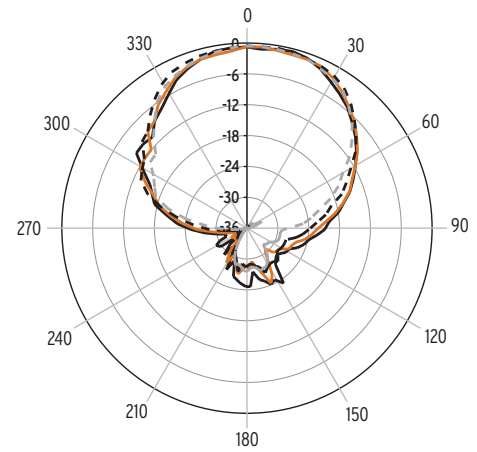
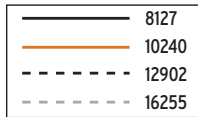
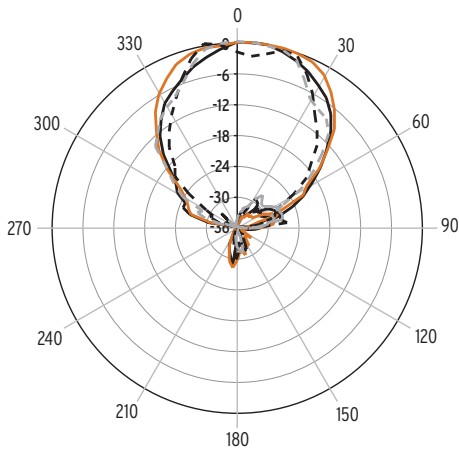

KPT-904

2-WAY BEHIND THE SCREEN CINEMA SYSTEM



Klipsch®

KLIPSCH PROFESSIONAL | CINEMA | DATA SHEET

VERTICAL 1/3 OCTAVE POLARS

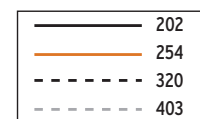
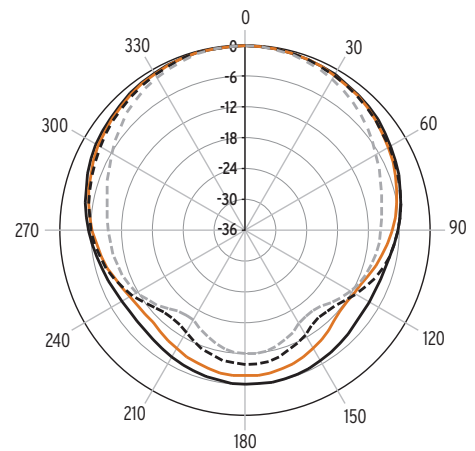
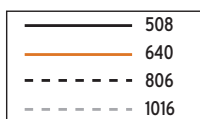
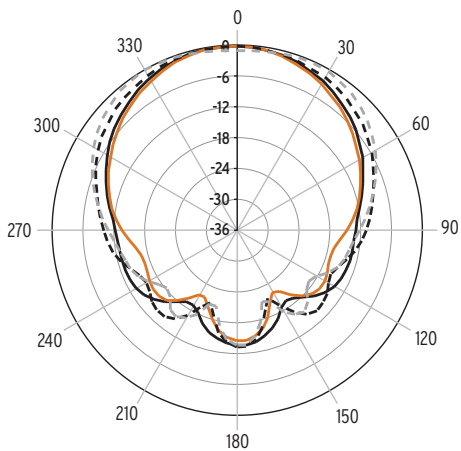
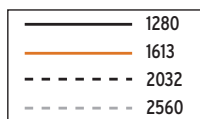
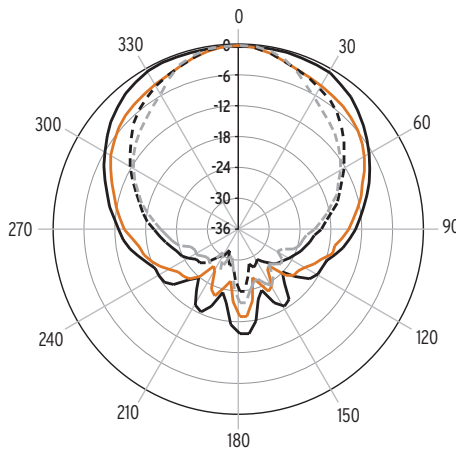
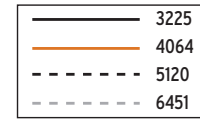
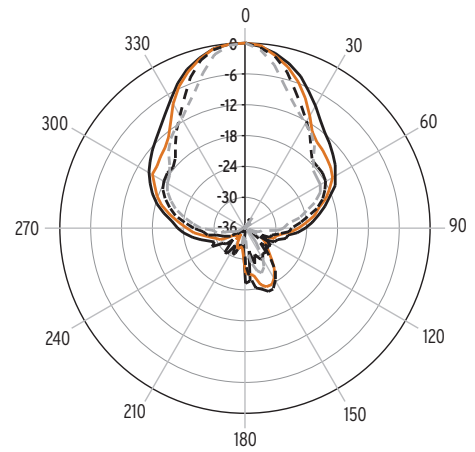
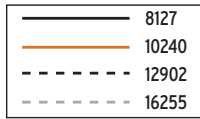
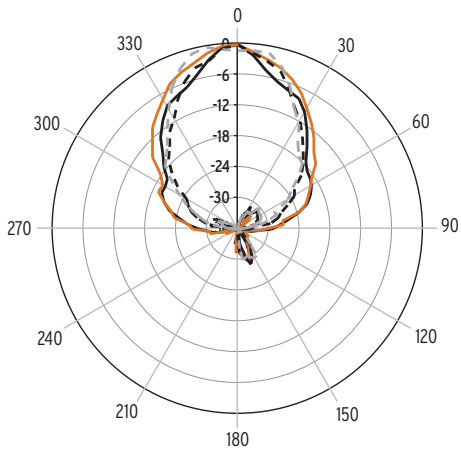

KPT-904

2-WAY BEHIND THE SCREEN CINEMA SYSTEM



KLIPSCH PROFESSIONAL | CINEMA | DATA SHEET

ARCHITECTURAL SPECIFICATIONS

The KI-398-RGL two-way professional cinema surround speaker system shall include an 15" (380 mm) K-48-ST low-frequency transducer utilizing a 3" (75 mm) voice coil, 104 ounce (2.95 kg) magnet and motor magnet assembly and a KDE-75-8P 3" (76.2 mm) titanium diaphragm high-frequency 60-ounce (1.70 kg) magnet compression driver mounted on a 90° X 50° injection molded modified Tractrix Horn. Signal shall be applied to the transducers via a full-range frequency-dividing network. The enclosure tuning shall be of a vented design.

Frequency response shall be 51 Hz to 18 kHz, +/- 3 dB, with the -10dBpoint at 38Hz, measured at three meters, half-space anechoic. The high-frequency dispersion angle shall be 90° X 50° nominal. Directivity shall be 8 dB. Sensitivity shall be 100dB SPL, measured at one meter, half-space anechoic, with a 2.83V input. Power handling shall be 600 watts (57 volts), to AES standards, continuous pink noise, 40 Hz to 10 kHz, 6 dB peaks. Calculated maximum continuous output at one meter shall be 126dB SPL. Nominal impedance shall be 8 ohms, with 5.5 ohms minimum at 90 Hz.

The internal passive crossover frequency shall be 750Hz with a slope of 24dB/octave on the low frequency and 24dB/octave on the high- frequency. Signal connections shall be made via a two point barrier strip.

The enclosure panels shall be CNC-fabricated using .75" (19mm) 7-ply natural hardwood plywood, assembled using rabbet and dado joinery. The motorboard baffle shall be 1" (2.54cm) molding grade MDF. Dimensions for the enclosure shall be 39" (99.1 cm) high by 16.0" (40.04 cm) deep by 19.8" (50.2cm) front width and 6.8" (17.2cm) rear width in a symmetrical trapezoidal shape, with both side panels angled at 22.5° Net weight shall be 78 lbs. (35.5kg).

Enclosure flying capability shall be provided via sixteen internal 3/8"-16 thread mounting points, 4 points per panel with additional compatibility with readily available commercial flying hardware.

The system shall be a Klipsch KI-398-RGL loudspeaker.

NEED HELP WITH YOUR PRO SYSTEM DESIGN?

You need to make the best impression, from the initial job quote through the completed installation. We can help choose the best Klipsch speakers for the application and help design a system that unleashes your venue's full potential.

Send us your plans or questions to us at:

PROSYSTEMDESIGN@KLIPSCH.COM

NOT A SUSPENSION POINT! 8 PLCS on each side and 8 PLCS on each top and bottom panels

3/8"-16 threaded hole suspension point 4 PLCS on each side panel and 4 PLCS on top and bottom panels

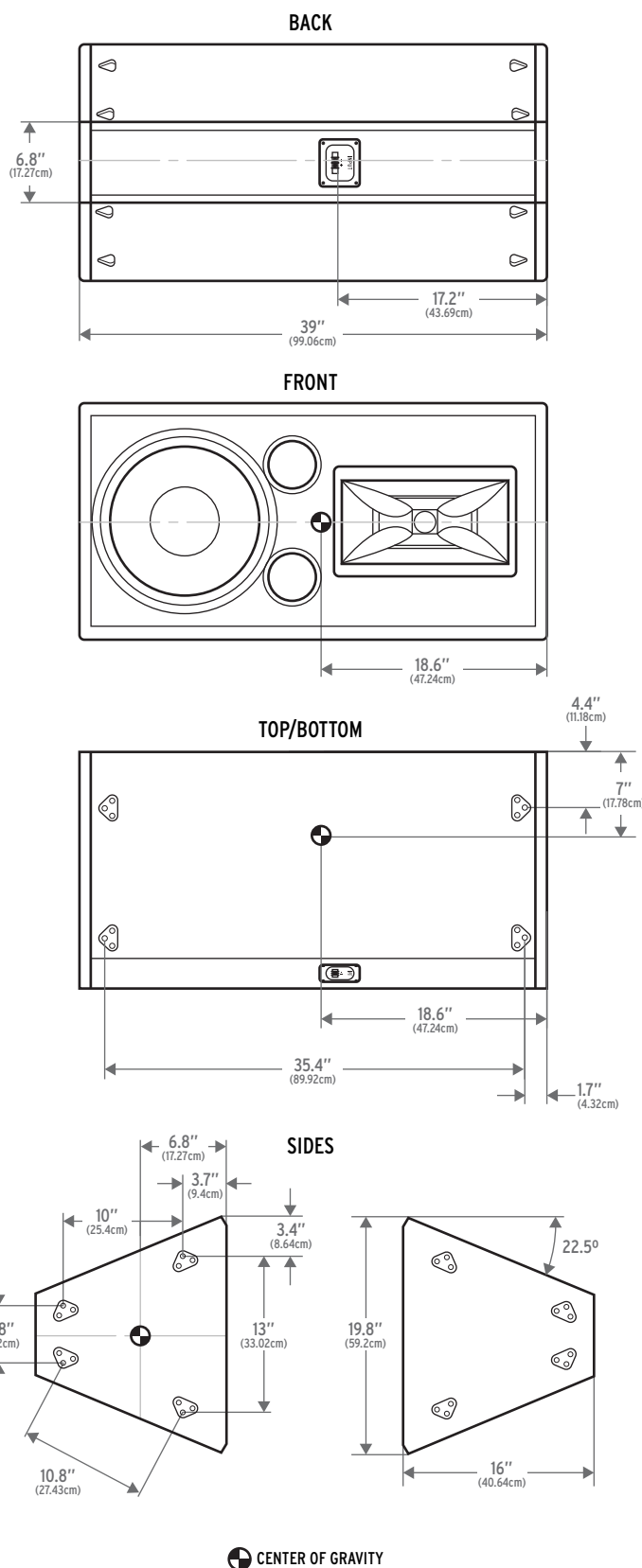

KPT-904

2-WAY BEHIND THE SCREEN CINEMA SYSTEM



Klipsch®

KLIPSCH PROFESSIONAL | CINEMA | DATA SHEET

ORDERING INFORMATION

KI-398-RGL

PART NUMBER	MODEL NAME	FINISH	PACKED QUANTITY	DESCRIPTION	UPC
1015031	KI-398-B-RGL	Black	1	Standard 8 ohm speaker	743878027792

KI-398 SIDE-PLATE MOUNTING KIT

PART NUMBER	MODEL NAME	FINISH	PACKED QUANTITY	DESCRIPTION	UPC
1061616	KI-398-RGL PLT Mounting Kit	Black	1	2 Side-Plates plus hardware	NA

KI-398-RGL CARTON DIMENSIONS

HEIGHT	41.5" (105.4cm)
WIDTH	21.0" (53.3cm)
DEPTH	17.0" (43.2cm)

KI-398 SIDE-PLATE MOUNTING KIT CARTON DIMENSIONS

HEIGHT	1" (2.5cm)
WIDTH	18.5" (33.0cm)
DEPTH	12.5" (31.8cm)